



## AKRAPOVIČ SLIP-ON & SLIP-ON MEGAPHONE EXHAUST SYSTEM for the SUZUKI GSX-R600, GSX-R750 2008-2009

Congratulations on purchasing an Akrapovič exhaust system. Please read these installation instructions carefully. If you have any trouble installing the system please contact your authorized dealer!

### IMPORTANT INFORMATION

#### Exclusion of Certain Liability

1. The manufacturer, importer or dealer shall not be liable for any incidental damage including personal injury or any other damages caused by improper installation or operation of the Akrapovič exhaust system. When installing the Akrapovič exhaust system be careful that the exhaust system does not touch other parts sensitive to high temperature.
2. Akrapovič makes no representation or warranties with regard to damage caused by the improper installation, use and maintenance of the Akrapovič exhaust system. The warranty is limited to defects recognized by our technical department and to normal use, and excludes items subject to normal wear (gaskets and damping wool). The guarantee is void in case of accident, modification, improper or competition use.
3. Do not attempt to install the Akrapovič exhaust system on a motorcycle for which it was not made or tested by Akrapovič.
4. When the exhaust system gets very hot during operation, be careful not to burn yourself on the exhaust system or parts which are in direct contact with it, even when the motor is not running. Also protect other people, especially children, from the injuries mentioned above.
5. In some cases Akrapovič exhaust system kits contain chemical products (ceramic anti-seizing grease; bolt sealant). Handle with care, do not inhale or swallow. Avoid excessive contact with skin, eyes or mucous membranes. Keep out of reach of children.
6. Technical specifications of Akrapovič exhaust systems and related products subject to change without notice.

#### Trademarks

The Akrapovič Exhaust System Technology logo is a registered trademark of Akrapovič d.d.

#### Akrapovic website

Information about Akrapovič exhaust systems and related products is available on the Akrapovič website at:

<http://www.akrapovic.com/>

#### Copyright

No part of the Akrapovič exhaust system or its documentation may be reproduced or distributed in any form or by any means without the prior written authorization of the Akrapovič company.

© Akrapovič, d.d. All rights reserved.

#### Symbols

The following symbols are used throughout these installation instructions:



**USE BOLT SEALANT;** Apply 3 to 4 small drops of bolt sealant onto the cleaned and degreased threads before tightening bolts. **WARNING! Avoid contact with skin, eyes and mucous membranes. Do not inhale fumes. Keep out of the reach of children.**



**USE ANTI-SEIZING GREASE (white tube);** Prevents seizing, corrosion and excessive wear between the titanium components of your exhaust system. **WARNING! Avoid eye contact. Avoid excessive skin contact. Keep out of the reach of children.**



**USE ANTI-SEIZE LEAD-FREE COPPER PASTE (black tube);** Provides trouble-free and long-lasting protection against seizing, corrosion and rusting of bolts, threaded ends, nuts, joints, etc. Also protects against vibration, wear and impact. **WARNING! Avoid eye contact. Avoid excessive skin contact. Keep out of the reach of children.**

## **INSTALLATION INSTRUCTIONS**

 **BEFORE INSTALLING CHECK SCHEMATIC OF THE EXHAUST SYSTEM!**

**!** IF ANY ITEMS IN THE AKRAPOVIC EXHAUST SYSTEM PACKAGE ARE MISSING PLEASE CONTACT YOUR AUTHORIZED DEALER. KEEP THE SCHEMATIC FOR FUTURE REFERENCE.

**!** THESE INSTALLATION INSTRUCTIONS MUST BE READ CAREFULLY IN ORDER TO ENSURE PROPER INSTALLATION AND OPERATION OF THE AKRAPOVIC EXHAUST SYSTEM.

**!** THE EXHAUST SYSTEM CAN BE EXTREMELY HOT. ALLOW THE MOTORCYCLE TO COOL DOWN BEFORE BEGINNING INSTALLATION.

 **WE ADVISE YOU TO LEAVE INSTALLATION TO A QUALIFIED SERVICEMAN. IMPROPER INSTALLATION MAY RESULT IN A SHORTER LIFETIME OF THE EXHAUST SYSTEM AND/OR DAMAGE TO THE MOTORCYCLE.**



T-handle 12 mm wrench  
T-handle 5 mm three hexagon key wrench  
Combination 12 mm wrench  
Spring puller

### **REMOVAL OF STOCK EXHAUST SYSTEM:**

1. Put the motorcycle on a side stand, we recommend a racing stand. Make sure, that surface is solid and flat.
2. Unscrew the bolt from the muffler bracket, untighten the bolt from the metal clamp at the muffler – collector joint, and remove the muffler (**Figure 1, 2, 3**).



Figure 1



Figure 2



Figure 3

**INSTALLATION OF THE AKRAPOVIČ SLIP-ON & MEGAPHONE EXHAUST SYSTEM:**

1. Coat the bolt and interior side of the metal clamp with Akrapovič anti-seize lead-free copper paste (black tube). Correctly install the metal clamp onto the link pipe and slide the link pipe onto the stock collector (**Figure 4**). For **Megaphone exhaust**: correctly install the metal clamp onto the megaphone and slide the megaphone onto the stock collector (**Figure 5, 6, 7**).



Figure 4



Figure 5

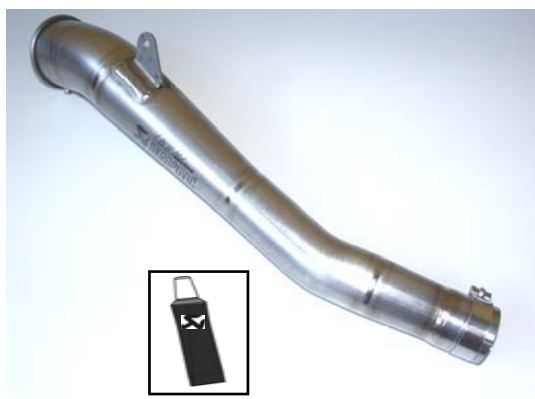

Figure 6



Figure 7

2. Position the muffler correctly and slide it onto the outlet side of the link pipe. (**Figure 8**).



Figure 8

3. Correctly position the carbon-fiber clamp and slide it onto the muffler - bear in mind **the left offset** of the carbon-fiber clamp viewed from the rear. **WARNING: open the clamp slightly wider than the diameter of the outer sleeve of the muffler – do not scrape it along the muffler outer sleeve!** Hand tighten the muffler carbon-fiber clamp onto the stock bracket using stock bolt, washer and nut. Attach the springs. (Figure 9, 10, 11).



Figure 9



Figure 10



Figure 11

4. Tighten the bolts of the metal clamp at the link pipe and on the carbon-fiber clamp/stock muffler bracket joint (Figure 12, 13). Make sure the muffler or the link pipe are not touching the frame, swing arm etc.



Figure 12



Figure 13

5. **For Megaphone exhaust:** tighten the megaphone bracket onto the stock bracket using stock bolt, washer and nut and tighten the bolt of the metal clamp at the stock collector (**Figure 14, 15, 16, 17**). Make sure the megaphone is not touching the frame, swing arm etc.



Figure 14



Figure 15

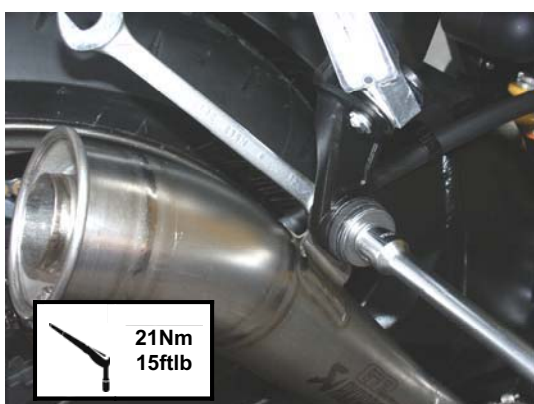

Figure 16



Figure 17

#### Final installation:

1. Clean grease spots:
  - a. Muffler – carbon-fiber outer sleeve: use a soft dry cloth.
  - b. Muffler – titanium outer sleeve: use a soft cloth sprayed with a multi-purpose spray lubricant (WD-40 or equivalent).
  - c. Muffler – carbon-fiber outlet cap: use a soft dry cloth.
  - d. Titanium link pipe and muffler inlet cap: use a soft cloth sprayed with a multi-purpose spray lubricant (WD-40 or equivalent).
  - e. Megaphone – use a soft cloth sprayed with a multi-purpose spray lubricant (WD-40 or equivalent).

Cleaning will prevent spots from burning onto the surface. Do not use aggressive chemical cleaners, because they can damage the sticker.

**WARNING! ; AFTER EXHAUST SYSTEM CHANGE, YOU SHOULD CHECK THE LAMBDA SENSOR VALUE. IF YOUR AIR TO FUEL RATIO IS TOO HIGH THE ENGINE COULD BE DAMAGED. WE RECOMMEND A FUEL INCREASE BY 10% (THIS SHOULD BE DONE BY SUZUKI SERVICE!).**

Position of the correctly installed Akrapovič **SLIP-ON MEGAPHONE** system (Figure 18).



Figure 18

Position of the correctly installed Akrapovič SLIP-ON system (Figure 19).



Figure 19

2. Check the operation of the brakes and suspension. Make sure all the bolts are sufficiently tightened. In case the exhaust system touches the cowling or other parts repeat the adjustment of the exhaust system or contact your authorized dealer.

**! IT IS NORMAL IF WHITE SMOKE COMES OUT OF THE MUFFLER ON FIRST OPERATION.**

**! DO NOT STAND BEHIND THE MUFFLER ON FIRST OPERATION.**

**! DO NOT USE AUTOMOTIVE WHEEL CLEANERS OR ANY CLEANING PRODUCTS WHICH CONTAIN ACIDIC ADDITIVES TO CLEAN AKRAPOVIC EXHAUST SYSTEMS.**

#### **MAINTENANCE OF THE AKRAPOVIČ EXHAUST SYSTEM**

1. Clean the titanium exhaust components with a multi-purpose spray lubricant (WD-40 or equivalent), carbon fiber exhaust components with soft and dry cloth and stainless steel components with soft cloth sprayed with contact cleaner, then wipe with soft and dry cloth. Do not use aggressive chemical cleaners, because they can damage the sticker. A change in the color of the exhaust system is normal due to the high temperatures.
2. The wearing out of the muffler silencing material depends on the type of the engine and riding style. Contact your dealer/serviceman if visible changes appear on muffler's outer sleeve or the noise level is increased.
3. Periodically make sure all the bolts and springs are sufficiently tight.

Suzuki GSX-R600 / 750 Slip-on system /Homologated, model year: 2008 - 2009

Product code: S-S6SO6-HZC  
S-S6SO6-HZT

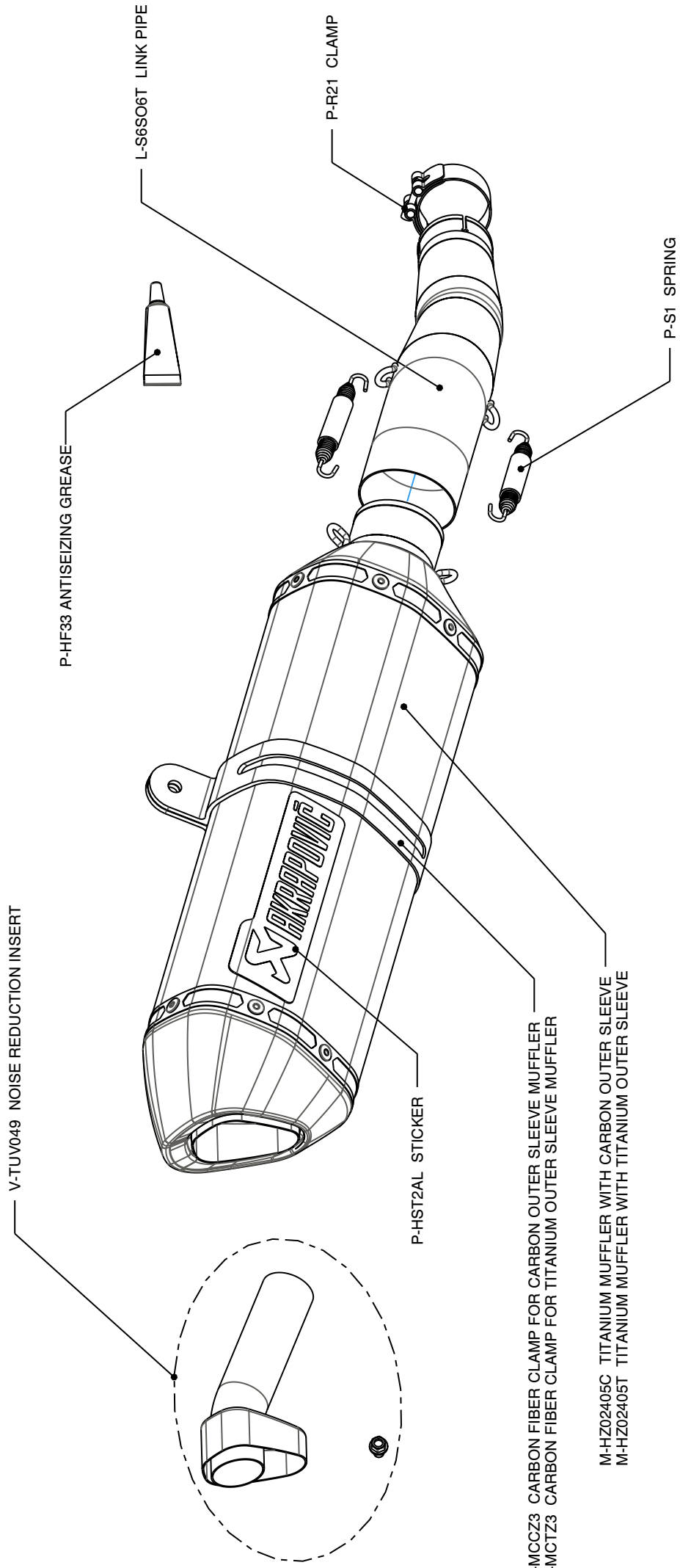



SUZUKI GSX-R600/750; MEGAFON OPEN; model year:2008/09

Product code: SM-S6S01T

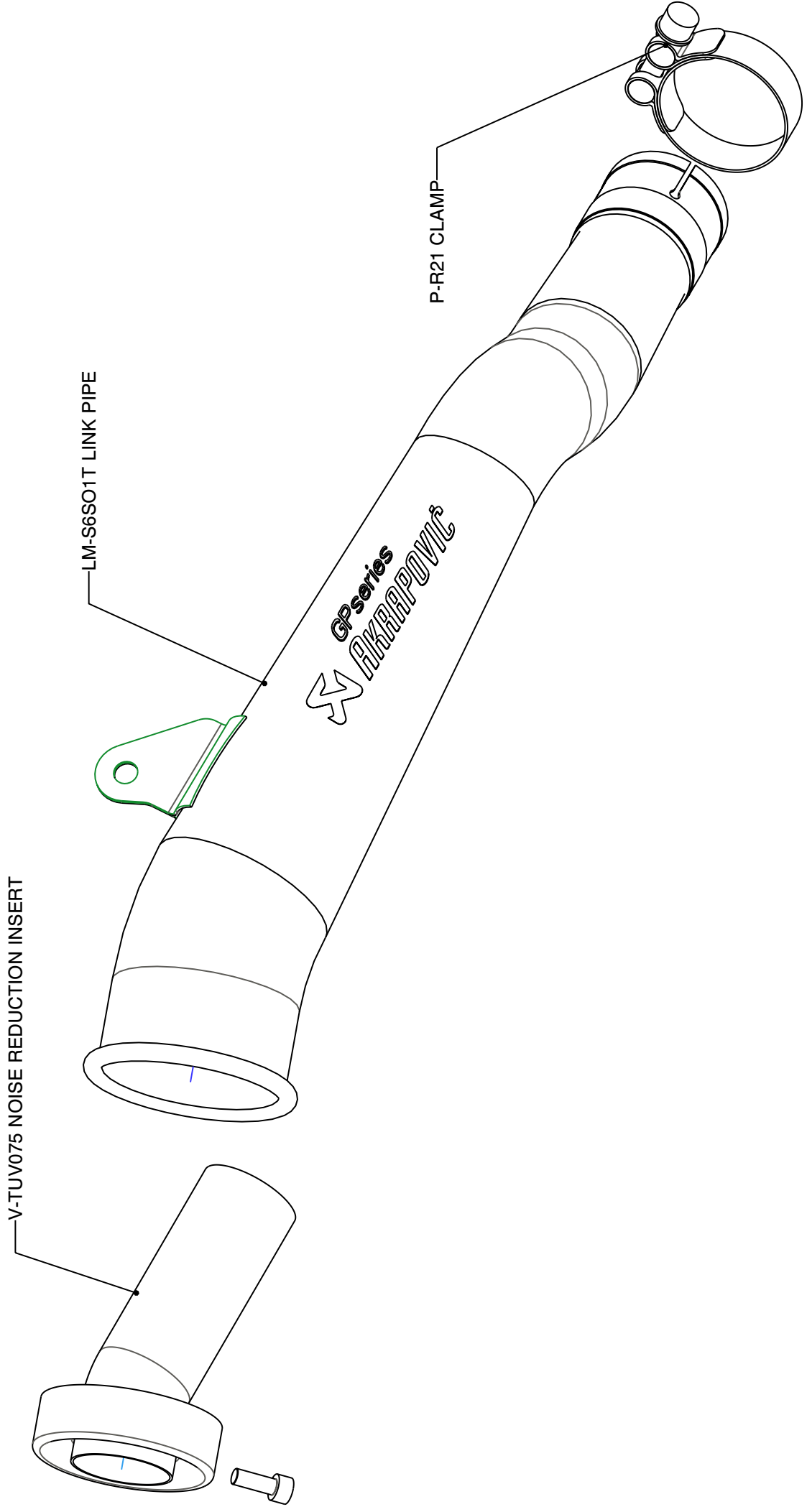

# SUZUKI GSX-R 600/750 Complete exhaust system/ Racing line tube set with street legal Slip-on muffler,

model year: 2008 - 2009

Product code: S-S6R7L-ZC/1  
S-S6R7L-ZT/1

WARNING! IN CASE OF COMBINATION WITH RACING TUBE SET, THE SLIP-ON HOMOLOGATION IS NOT VALID!

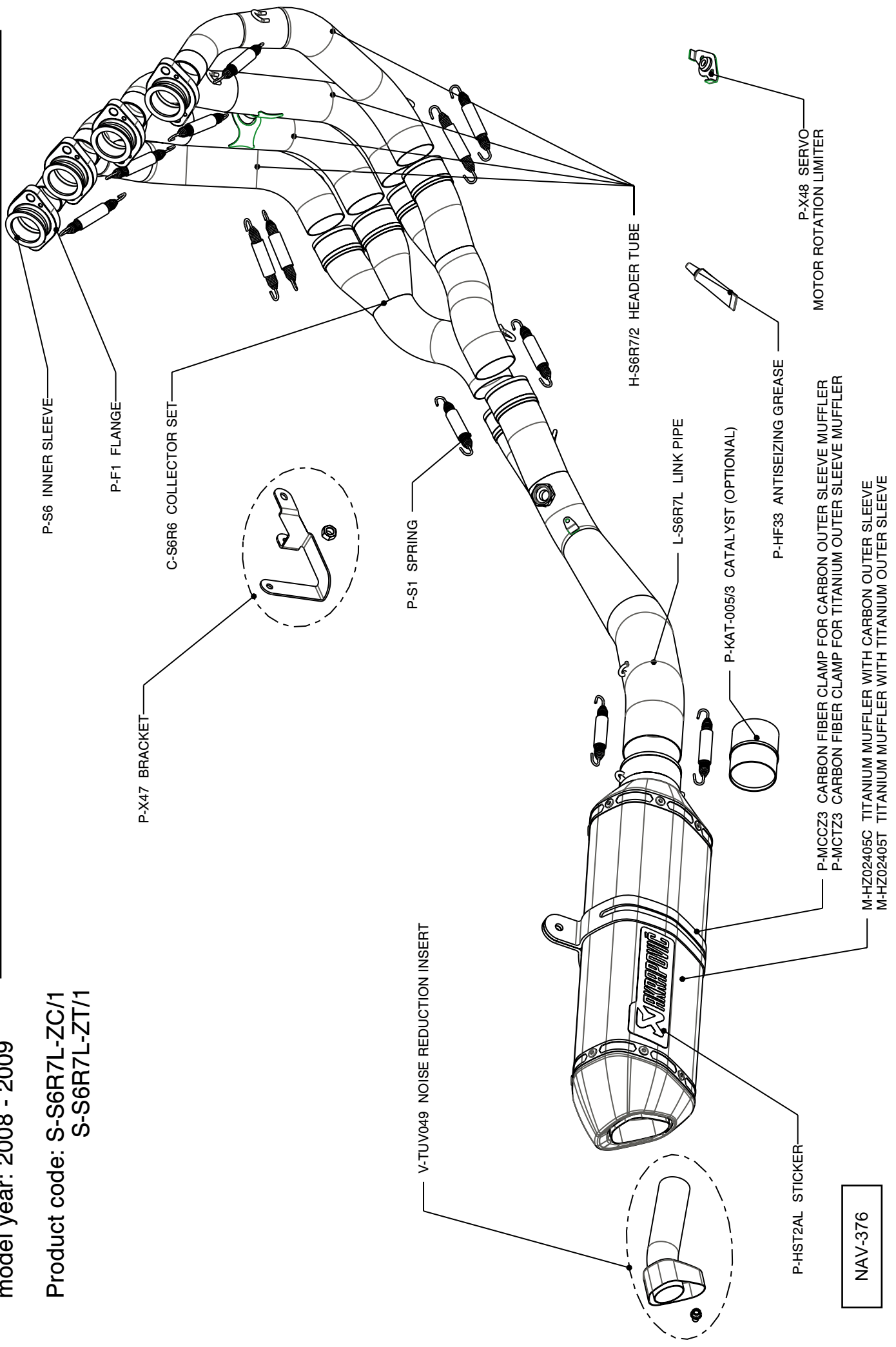

# SUZUKI GSX-R 600/ 750 Complete exhaust system/ Evolution line tube set with street legal Slip-on muffler,

model year: 2008 -2009

Product code: S-S6RFT7TL-ZC/1  
S-S6RFT7TL-ZT/1

WARNING! IN CASE OF COMBINATION WITH EVOLUTION TUBE SET, THE SLIP-ON HOMOLOGATION IS NOT VALID!

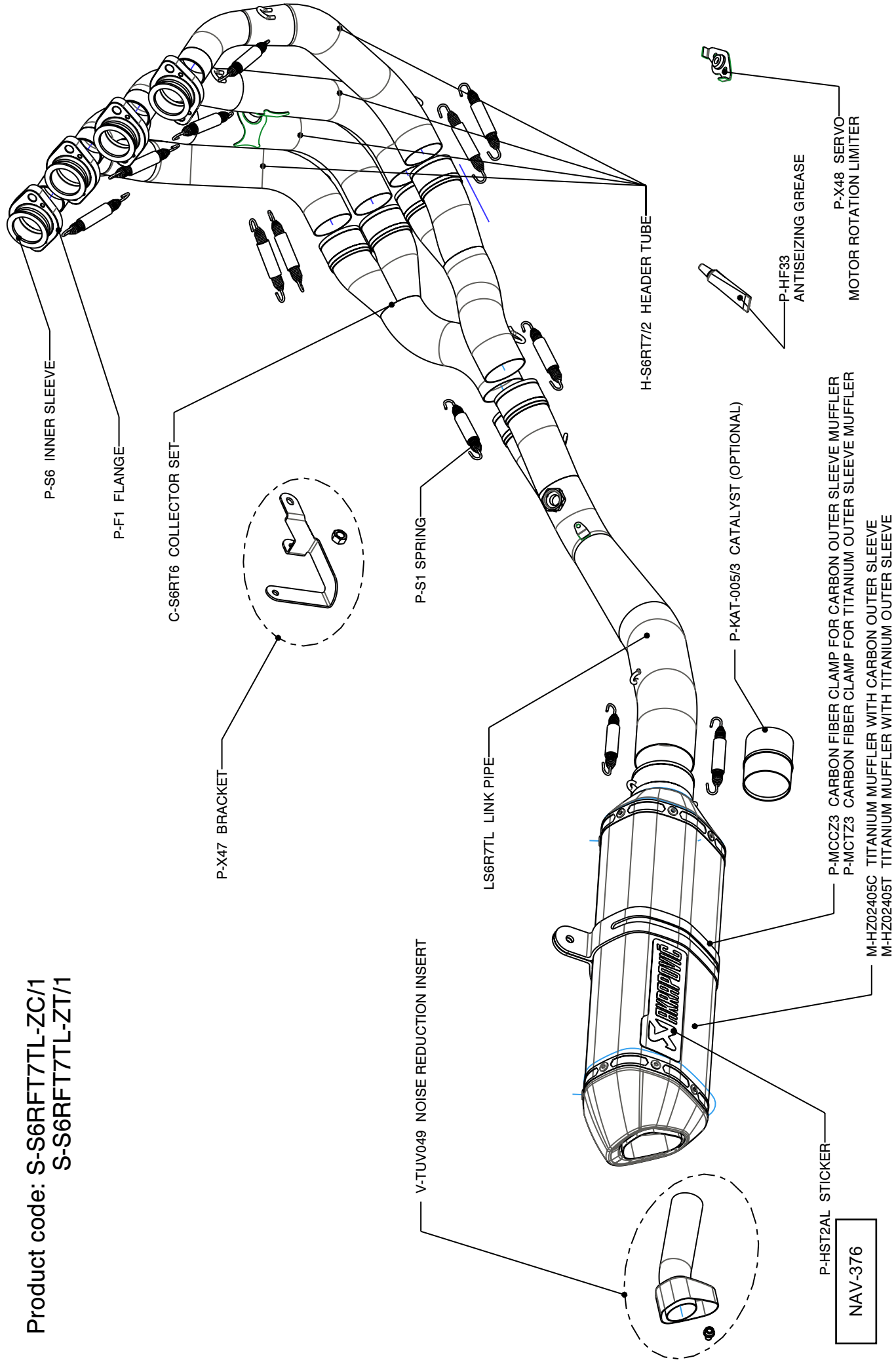

P-HST2AL STICKER  
NAV-376